

# KNÜRR ELICON® CLASSIC

95 to 117



## MODULAR WORKSTATION SYSTEM

Especially for engineering workstations or in electronic laboratories offers our comprehensive product range optimal solutions for a customized, ergonomic and efficient workstation.

The **modular design** enables a wide variety of configurations and guarantees the highest degrees of flexibility. Combinations of tables can be retrofitted or modified at any time and without considerable effort.

**High quality materials** with extruded aluminum profiles in

combination with die-cast aluminum stabilizers ensure a **maximum degree of stability and sturdiness**.

**Ergonomic details** simplify daily work in various situations and environments.

A **comprehensive range of accessories** completes the Knürr Elicon workstation system: flat screen holders, PC and 19-inch rack containers, workstation lighting, usable storage trays, cable routing ducts and other extras.

## Knürr Elicon® Strong points

- **Future-proof modular design**
  - Expand your existing table combinations, modify your current installation or supplement it with new accessories. The modular design and multi-functional T-grooves give you all the options for future upgrades.
- **Perfect ergonomics**
  - Freely selectable working height in 20 mm increments (can be changed retroactively), great ergonomics guaranteed.
- **Convenient cable management**
  - Spacious horizontal cable ducts with convenient access from above via sliding sections. Routing through vertical cable troughs via detachable covers on the inside and outside of the side sections.
- **Providing electricity**
  - Cable troughs and crosspieces are equipped with a cap extrusion for easy mounting and attachment of socket strips and installation components.
- **Flat-packed kit**
  - Preassembled modules are supplied as a flat-packed kit. This saves freight space and reduces time and space required for assembly.
- **Easy assembly**
  - Screw connections facilitate quick assembly. Simple assembly instructions describe the process.
- **Different working surface depths**
  - Working surface depths from 700 mm to 1000 mm (in 100 mm increments) allow for custom room planning in accordance with your requirements.
- **Maximum stability**
  - More than 20 years of proven stability of Elicon extruded aluminum profiles and die-cast stabilizers in conjunction with sheet steel make this system a reliable and stable choice.



CON20105



CON20103



CON20104



CON20107



CON20106

## Knürr Elicon®

### Connector Side Panels/Closing Side Panels

- **Connector/closing side panels**
  - Vertical cable routing in the spacious cable duct
  - Sheet steel cable duct covers with hinge function for easy cabling
  - Mounted superstructures (rear), add-on levels, and other components
  - Mounting option for additional foot stabilizer at the rear to increase stability with add-ons
  - Preassembled lock strips for simple and secure worktop mounting (680–760 mm, increment 20 mm). Any work height can be set at any time simply by turning a screw
- **Connector Side Panels**
  - Segmented cable duct cover on the outside and inside
- **Closing Side Panels**
  - Full-length cable duct cover on the outside
  - Segmented cable duct cover on the inside
- **Variants**
  - Type 1**
    - Side panel with short stabilizer for worktops with depth 700 mm
  - Type 2**
    - Side panel with long stabilizer for worktops with depths 800/900/1000 mm
- **Material/finish**
  - Extruded aluminum with die cast aluminum stabilizer and head piece, antistatic powder-coated texture
  - Cable duct cover: sheet steel, rolled, antistatic powder-coated texture
- **Color combination**
  - Final digit of order number .2:**
    - Metal parts: RAL 7035 light grey
    - Design elements: RAL 5003 sapphire blue
  - Final digit of order number .9:**
    - Metal parts and design elements: RAL 7021 dark grey
- **How supplied**
  - Preassembled modules



CON20105

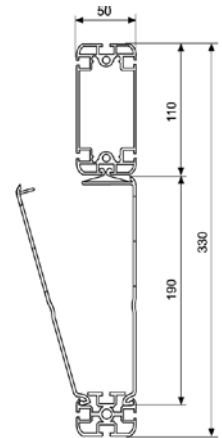

CON00065

#### Knürr Elicon® Connector Side Panels

W	H	D	Model	Order-no.	UP
760	650		Type 1	04.252.150.x	1 unit
760	800		Type 2	04.252.151.x	1 unit
1250	800		Typ 2	04.252.155.x	1 unit
1656	800		Type 2	04.253.151.x	1 unit
2064	800		Type 2	04.253.152.x	1 unit

#### Knürr Elicon® Closing Side Panels

W	H	D	Model	Order-no.	UP
760	650		Type 1	04.252.160.x	1 unit
760	800		Type 2	04.252.161.x	1 unit
1250	800		Typ 2	04.252.165.x	1 unit
1656	800		Type 2	04.253.161.x	1 unit
2064	800		Type 2	04.253.162.x	1 unit

### Knürr Elicon® Side Piece Cover, Full-Length Optional for external side piece

- **Material/Finish**
  - Sheet steel, rolled, antistatic powder-coat textured
- **Colour combination**
  - Final digit of order number .1:**
    - RAL 7035 light-grey
  - Final digit of order number .9:**
    - RAL 7021 dark-grey
- **Supply schedule**
  - 1 Side piece

W	H	D	Order-no.	UP
760			04.250.362.x	1 unit
1250			04.250.367.x	1 unit
1656			04.250.364.x	1 unit
2064			04.250.365.x	1 unit



CON20107

## Knürr Elicon® Working Level

- Working level designed as sliding section for convenient access to the horizontal cable duct
  - The working level can be mounted at any height between two side panels and can also be varied in the height at any time
  - Worktop (30 mm) with ergonomically shaped front edge
  - Spacious horizontal cable duct, can be accessed via sliding worktop and folding mechanism
  - Cable duct with integrated C-rail for mounting installation components and mounting slot for general accessories
- **Material / Finish**
    - Crosspiece: extruded aluminium, antistatic, powder-coated texture
    - Support arms: sheet steel, antistatic powder-coated texture
    - Worktop: three layer particle board, FP/Y E1 version, fire protection class B2
    - Worktop cover: high pressure plastic laminate
    - Cable duct, horizontal: sheet steel, rolled, antistatic, powder-coated texture
  - **Colour combination**
    - Final digit of order number .1:**
      - Worktop: light-grey
      - Metal parts: RAL 7035 light-grey
    - Final digit of order number .5:**
      - Worktop: beech finish
      - Metal parts: RAL 7021 dark-grey
  - **Load rating**
    - 1500 N (static surface load)
  - **Standards**
    - DIN 68761 for worktop
    - EN 438 HGS for high pressure plastic laminate
    - EN 438 class HGS for coating material
  - **Supply schedule**
    - 1 Worktop
    - 1 Crosspiece
    - 2 Desk stabilizers
    - 1 Cable duct
    - 1 Detailed mounting instructions
    - Mounting material
  - **How supplied**
    - Preassembled modules

W	H	D	Order-no.	UP
800	700		04.252.100.x	1 unit
1200	700		04.252.101.x	1 unit
1600	700		04.252.102.x	1 unit
1800	700		04.252.103.x	1 unit
2000	700		04.252.104.x	1 unit
800	800		04.252.105.x	1 unit
1200	800		04.252.106.x	1 unit
1600	800		04.252.107.x	1 unit
1800	800		04.252.108.x	1 unit
2000	800		04.252.109.x	1 unit
800	900		04.252.110.x	1 unit
1200	900		04.252.111.x	1 unit
1600	900		04.252.112.x	1 unit
1800	900		04.252.113.x	1 unit
2000	900		04.252.114.x	1 unit
800	1000		04.252.115.x	1 unit
1200	1000		04.252.116.x	1 unit
1600	1000		04.252.117.x	1 unit
1800	1000		04.252.118.x	1 unit
2000	1000		04.252.119.x	1 unit

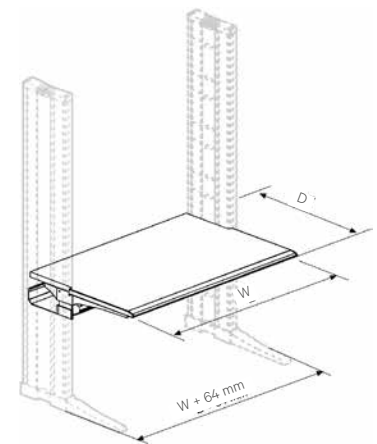

CON00057

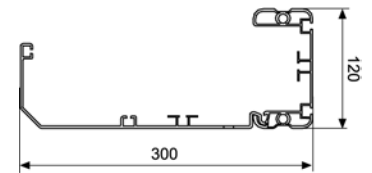

CON00061

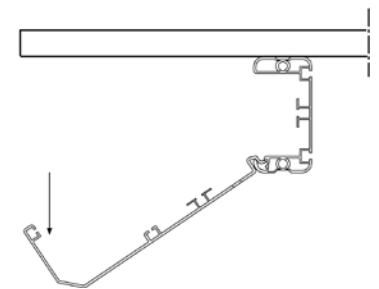

CON00062

**Dimensions in mm:** W = Width  
H = Height  
D = Depth  
h = Installation height  
d = Useful depth  
L = Length  
HU = Standard height unit, 1 HU = 44.45 mm  
19" = 482.6 mm, (ideal for 19" components in acc. with DIN 41494)  
UP = Unit of packaging  
kg = Weight

**Conversion:** 1 inch = 25.4 mm  
1 pound = 453.6 g  
Replace „x“ with the number of your color choice



## Base Routing Plate

- **Material / Finish**
  - Sheet steel, powder-coated texture
- **Colour**
  - Final digit of order number .1:**
    - RAL 7035 light grey
  - Final digit of order number .9:**
    - RAL 7021 dark grey
- **Supply schedule**
  - 1 base routing plate
  - 2 quick connectors
- **Note**
  - Serves as cable cover

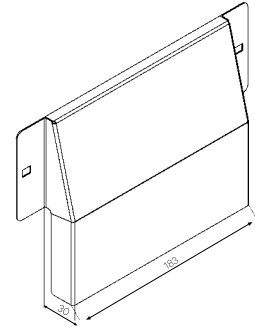

CON20087

Order-no.	UP
04.252.604.x	1 unit

## Knürr Elicon® Superstructure Level Standard

- For utilizing the area above the worktop as storage and functional surface with additional cabling option
- Worktop height easily adjustable
- Cable duct integrated in the crosspiece
- Tiltable 0–10°
- Worktop: 30 mm
- **Material / Finish**
  - Superstructure worktop: three layer particle board, FP/Y E1 version, fire protection class B2, melamine coated (directly coated) edge banding, ABS 3mm fine textured, matt
  - Crosspiece: extruded aluminium, antistatic, powder-coated texture
  - Cable duct, horizontal: sheet steel, rolled, antistatic powder-coated texture
- **Colour combination**
  - Final digit of order number .1:**
    - Superstructure worktop: light-grey
    - Metal parts: RAL 7035 light-grey
  - Final digit of order number .5:**
    - Superstructure worktop: beech finish
    - Metal parts: RAL 7021 dark-grey
- **Load rating**
  - 750 N (static surface load)
- **Standards**
  - DIN 68761 for superstructure worktop
  - DIN 68765 for direct coating
- **Note**
  - Caution with use in tilted state; use edge strip to prevent sliding
- **Supply schedule**
  - 1 Superstructure worktop
  - 1 Crosspiece
  - Mounting material
- **How supplied**
  - Pre-assembled modules

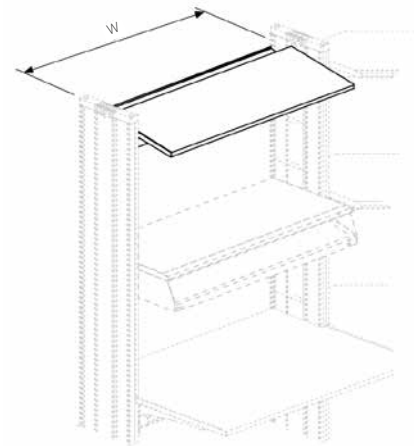

CON00063

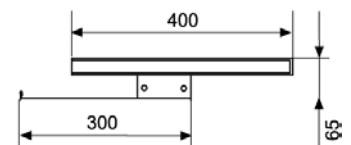

CON00075

W	H	D	Model	Order-no.	UP
800		400	Standard	04.258.015.x	1 unit
1200		400	Standard	04.258.016.x	1 unit
1600		400	Standard	04.258.017.x	1 unit
1800		400	Standard	04.258.018.x	1 unit
2000		400	Standard	04.258.019.x	1 unit

## Knürr Elicon® Superstructure Level System

- Working level designed as sliding top for convenient access to the horizontal cable duct
  - For utilizing the space above the worktop as storage
  - Stable crosspiece with spacious, folding, and consequently easily accessible cable duct
  - Easy integration of system components for perfect electricity provision with C-rails and mounting slots
  - Worktop height easily adjustable
  - Can be fitted at any time with keyboard shelves
  - Worktop thickness: 30 mm
- **Material / Finish**
    - Superstructure worktop: three layer particle board, FP/Y E1 version, fire protection class B2, melamine coated (directly coated) edge banding, ABS 3mm fine textured, matt
    - Crosspiece: extruded aluminium, antistatic, powder-coated texture
    - Support arms: sheet steel, antistatic powder-coated texture
    - Cable duct, horizontal: sheet steel, rolled, antistatic powder-coated texture
- **Colour combination**
    - Final digit of order number .1:**
      - Superstructure worktop: light-grey
      - Metal parts: RAL 7035 light-grey
    - Final digit of order number .5:**
      - Superstructure worktop: beech finish
      - Metal parts: RAL 7021 dark-grey
  - **Load rating**
    - 1500 N (static surface load)
  - **Standards**
    - DIN 68761 for superstructure worktop
    - DIN 68765 for direct coating
  - **Supply schedule**
    - 1 Superstructure
    - 2 Stabilizers
    - 1 Crosspiece
    - 1 Cable duct
    - Mounting material
  - **How supplied**
    - Pre-assembled modules

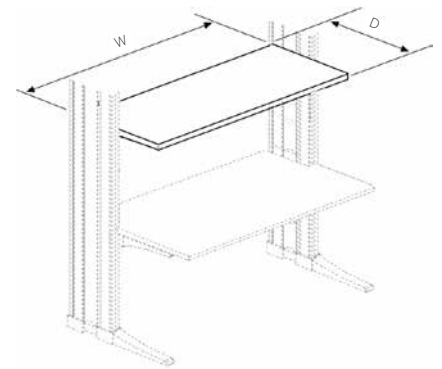

CON00064

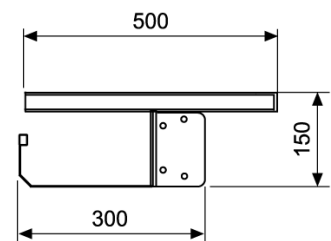

CON00037

W	H	D	Order-no.	UP
800		500	04.258.025.x	1 unit
1200		500	04.258.026.x	1 unit
1600		500	04.258.027.x	1 unit
1800		500	04.258.028.x	1 unit
2000		500	04.258.029.x	1 unit

## Edge Strip

- Prevents equipment set up on the tilted structural rack from sliding
  - Suitable for Knürr Dacobas® and Knürr Elicon®
- **Supply schedule**
    - 1 edge strip
    - Mounting material

W	w	Order-no.	UP
800	730	04.258.150.1	1 unit
1200	1130	04.258.151.1	1 unit
1600	1530	04.258.152.1	1 unit
1800	1730	04.258.153.1	1 unit
2000	1930	04.258.154.1	1 unit

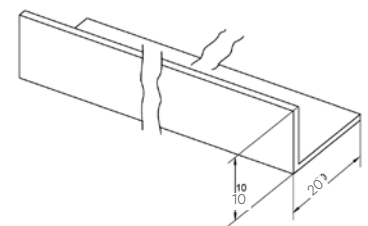

RAP00057

**Dimensions in mm:** W = Width  
H = Height  
D = Depth  
h = Installation height  
d = Useful depth  
L = Length  
HU = Standard height unit, 1 HU = 44.45 mm  
19" = 482.6 mm, (ideal for 19" components in acc. with DIN 41494)  
UP = Unit of packaging  
kg = Weight

**Conversion:** 1 inch = 25.4 mm  
1 pound = 453.6 g  
Replace .x' with the number of your color choice

## Knürr Elicon® Computer Platform Fixed

- Low space requirement in the height
  - Mounting height variable
  - Can be upgraded at any time
  - Easy mounting
  - Can be mounted on the front or rear
- **Material / Finish**
    - Sheet steel with reinforced extrusions on the underside, antistatic powder-coated texture
  - **Colours**
    - Final digit of order number .1:**
      - RAL 7035 light-grey
    - Final digit of order number .9:**
      - RAL7021 dark-grey
- **Load rating**
    - 1500 N (static surface load)
  - **Note**
    - The lowest mounting position is 80 mm (min. floor clearance)
  - **Supply schedule**
    - 1 Platform
    - Mounting material
  - **How supplied**
    - Flat-packed kit

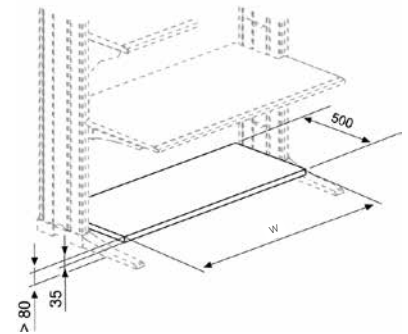

CON00055

W	H	D	w	Model	Order-no.	UP
800		500	750	Fixed	04.258.074.x	1 unit
1200		500	1150	Fixed	04.258.075.x	1 unit
1600		500	1550	Fixed	04.258.076.x	1 unit
1800		500	1750	Fixed	04.258.077.x	1 unit
2000		500	1950	Fixed	04.258.078.x	1 unit

## Knürr Elicon® Add-On Level Height adjustable and tiltable

- Can be upgraded at any time
  - Height variable for exact adjustment to operator and hardware
  - Extremely stable construction with integrated cable trough
  - Useful depth: 590 mm
  - Can be delivered for desk width, 800–2000 mm
  - Variable tilt adjustment without tools at increments: 0°/7.5°/15°
  - Secure cable management through spacious cable trough and cable ports in the shelf
- **Material / Finish**
    - Superstructure worktop: three layer particle board, FP/Y E1 version, fire protection class B2
    - Worktop coating: high pressure plastic laminate
    - Support bracket: sheet steel, holed, antistatic powder-coated texture
    - Crosspiece with integrated cable trough: sheet steel, antistatic powder-coated texture
  - **Colour combination**
    - Final digit of order number .2:**
      - Superstructure: light-grey
      - Support bracket: RAL 5003 sapphire blue
      - Metal parts: RAL 7035 light-grey
    - Final digit of order number .5:**
      - Superstructure: beech finish
      - Metal parts and support bracket: RAL 7021 dark-grey
  - **Load rating**
    - 1500 N (static surface load)
  - **Standards**
    - DIN 68761 for worktop
    - EN 438 HGS class for high pressure plastic laminate
  - **Attention!**
    - With tilted use of monitors and other components set up on the add-on level, secure against sliding by using an anti-slide restrainer, for example.
  - **Supply schedule**
    - 1 Complete add-on level, pre-assembled
    - 2 Foot stabilizers, short
    - Mounting material
  - **How supplied**
    - Flat-packed kit

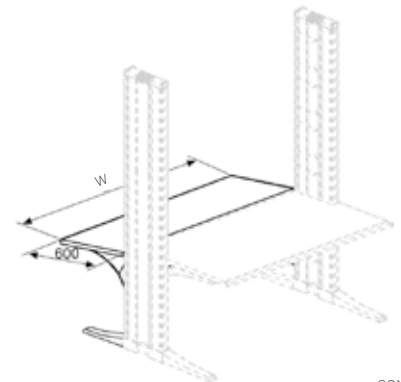

CON00035

W	H	D	Order-no.	UP
800		600	04.258.069.x	1 unit
1200		600	04.258.070.x	1 unit
1600		600	04.258.071.x	1 unit
1800		600	04.258.072.x	1 unit
2000		600	04.258.073.x	1 unit



## Knürr Elicon® Suspension Cabinet

- For mounting at any height between the side panels
- The sliding doors on smooth-running plastic guide can be locked with plunger cylinder lock

### Material / Finish

- Main unit and sliding doors: three layer particle board, FP/Y E1 version, fire protection class B2, melamine coated (directly coated) edge banding, ABS 3mm fine textured, matt
- Mounting bracket: sheet steel, antistatic powder-coated texture

### Colour combination

#### Final digit of order number .1:

- Main unit, doors and handles: RAL 7035 light-grey

#### Final digit of order number .5:

- Main unit and handles: RAL 7021 dark-grey
- Doors: beech finish

### Load rating

- 600 N (static surface load)

### Standards

- DIN 68761 for main unit and sliding doors
- DIN 68765 for direct coating

### Supply schedule

- 1 Suspension cabinet complete with mounting bracket
- Mounting material

### How supplied

- Pre-assembled modules

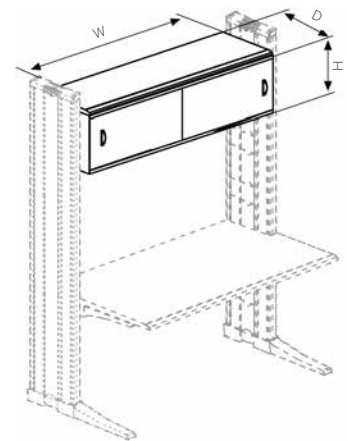

CON00047

H	D	W	w	h	d	Order-no.	UP
400	420	752	2x340	350	350	04.260.000.x	1 unit
400	420	1152	2x540	350	350	04.260.001.x	1 unit
400	420	1552	2x740	350	350	04.260.002.x	1 unit

## Knürr Elicon® Add-On Level Fixed

- For later extension of the worktop depth
- Height variable for exact adjustment to operator and hardware

### Material / Finish

- Superstructure worktop: three layer particle board, FP/Y E1 version, fire protection class B2
- Worktop coating: high pressure plastic laminate
- Support bracket: sheet steel, holed, antistatic powder-coated texture

### Colour combination

#### Final digit of order number .2:

- Add-on shelf: light-grey
- Support bracket: RAL 5003 sapphire blue
- Metal parts: RAL 7035 light-grey

#### Final digit of order number .5:

- Add-on shelf: beech finish
- Metal parts and support bracket: RAL 7021 dark-grey

### Load rating

- 750 N (static surface load)

### Standards

- DIN 68761 for worktop
- EN 438 HGS class for high pressure plastic laminate

### Supply schedule

- 1 Add-on shelf
- 2 Support brackets
- 2 Foot stabilizers, short
- Mounting material

### How supplied

- Flat-packed kit

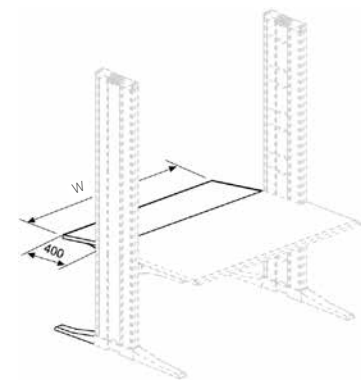

CON00034

W	H	D	Order-no.	UP
800		400	04.258.080.x	1 unit
1200		400	04.258.081.x	1 unit
1600		400	04.258.082.x	1 unit
1800		400	04.258.083.x	1 unit
2000		400	04.258.084.x	1 unit

**Dimensions in mm:** W = Width  
 H = Height  
 D = Depth  
 h = Installation height  
 d = Useful depth  
 L = Length

HU = Standard height unit, 1 HU = 44.45 mm, 19" = 482.6 mm, (ideal for 19" components in acc. with DIN 41494)

UP = Unit of packaging  
 kg = Weight

**Conversion:** 1 inch = 25.4 mm  
 1 pound = 453.6 g

Replace 'x' with the number of your color choice

## Knürr Elicon® - Perforated Rear Panels

- As privacy screen for foot area and above the working surface
- Can be attached and removed without tools
- Flexible combinations possible

### Material / Finish

- Steel panel, powder-coated

### Color combination

#### Last digit of Order-No. 1:

- RAL 7035 Light gray

#### Last digit of Order-No. 9:

- RAL 7021 Black gray

### Supply schedule

- 1 rear panel

### Note

- Order 1 mounting set per Elicon side section Order-No. 04.258.109.9 for every Elicon rear panel

W	H	Variant	Order-no.	UP
800	682	Elicon rear panel, bottom	04.258.110.x	1 unit
1000	682	Elicon rear panel, bottom	04.258.111.x	1 unit
1200	682	Elicon rear panel, bottom	04.258.112.x	1 unit
1400	682	Elicon rear panel, bottom	04.258.113.x	1 unit
1600	682	Elicon rear panel, bottom	04.258.114.x	1 unit
1800	682	Elicon rear panel, bottom	04.258.115.x	1 unit
2000	682	Elicon rear panel, bottom	04.258.116.x	1 unit
800	433	Elicon rear panel, top	04.258.120.x	1 unit
1000	433	Elicon rear panel, top	04.258.121.x	1 unit
1200	433	Elicon rear panel, top	04.258.122.x	1 unit
1400	433	Elicon rear panel, top	04.258.123.x	1 unit
1600	433	Elicon rear panel, top	04.258.124.x	1 unit
1800	433	Elicon rear panel, top	04.258.125.x	1 unit
2000	433	Elicon rear panel, top	04.258.126.x	1 unit
Mounting set (2x suspending blocks)			04.258.109.9	1 set

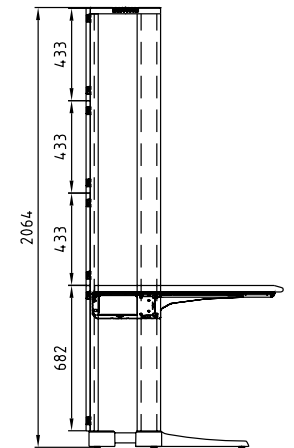
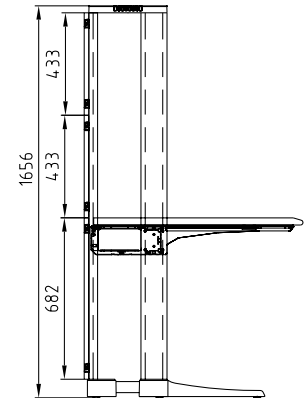
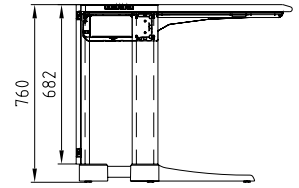

CON20132

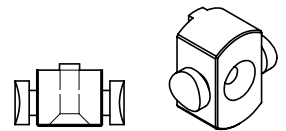

Suspending block for rear panel

CON20133



CON20109

**Dimensions in mm:** W = Width  
 H = Height  
 D = Depth  
 h = Installation height  
 d = Useful depth  
 L = Length  
 HU = Standard height unit, 1 HU = 44.45 mm  
 19" = 482.6 mm, (ideal for 19" components in acc. with DIN 41494)  
 UP = Unit of packaging  
 kg = Weight

**Conversion:** 1 inch = 25.4 mm  
 1 pound = 453.6 g  
 Replace „x“ with the number of your color choice

## Knürr Elicon® System Components, Corners

- The ergonomically shaped front edge ensures optimal working conditions
  - Height variable for exact adjustment to operator and hardware
  - With support arms for direct connection to the side panels
  - Spacious horizontal cable duct, can be accessed via removeable corner panel and folding mechanism
  - Cable duct with integrated C-rail for mounting installation components and T-slot for mounting general accessories
  - With side panels which can also be used as workstation end points
- **Material / Finish**
    - Crosspiece: extruded aluminium, antistatic, powder-coated texture
    - Support arms: sheet steel, antistatic powder-coated texture
    - Worktop: three layer particle board, FP/Y E1 version, fire protection class B2
    - Worktop coating: high pressure plastic laminate
    - Cable duct, horizontal: sheet steel, rolled, antistatic powder-coated texture
  - **Colour combination**
    - **Final digit of order number .1:**
      - Worktop: light-grey
      - Metal parts: RAL 7035 light-grey
    - **Final digit of order number .5:**
      - Worktop: beech finish
      - Metal parts: RAL 7021 dark-grey
  - **Load rating**
    - 1500 N (static surface load)
  - **Standards**
    - DIN 68761 for worktop
    - EN 438 HGS class for high pressure plastic laminate
  - **Supply schedule**
    - 1 Corner panel
    - 1 Worktop support complete with crosspiece
    - 2 Stabilizers and cable duct
    - Mounting material
  - **How supplied**
    - Pre-assembled modules

A	Model	Order-no.	UP
700	30°	04.252.510.x	1 unit
800	30°	04.252.500.x	1 unit
900	30°	04.252.501.x	1 unit
1000	30°	04.252.502.x	1 unit
700	45°	04.252.511.x	1 unit
800	45°	04.252.503.x	1 unit
900	45°	04.252.504.x	1 unit
1000	45°	04.252.505.x	1 unit
700	60°	04.252.512.x	1 unit
800	60°	04.252.506.x	1 unit
900	60°	04.252.507.x	1 unit
1000	60°	04.252.508.x	1 unit
700	90°, angled	04.252.550.x	1 unit
800	90°, angled	04.252.551.x	1 unit
900	90°, angled	04.252.552.x	1 unit
1000	90°, angled	04.252.553.x	1 unit

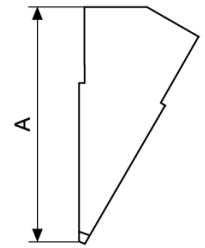

CON00023

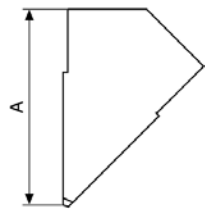

CON00024

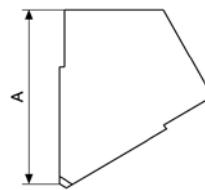

CON00025

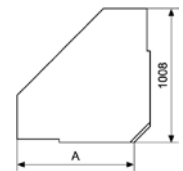

CON00030

## Knürr Elicon® Trapezoid Corner

- ESD version for discharging electrostatic charges
  - The ergonomically formed front edge ensures optimal working conditions
  - Height variable for exact adjustment to operator and hardware
  - With support arms for direct connection to the side panels
  - Spacious horizontal cable duct, can be accessed via removeable corner panel and folding mechanism
  - Cable duct with integrated C-rail for mounting installation components and T-slot for mounting general accessories
  - With side panels which can also be used as workstation end points
- **Material / Finish**
    - Crosspiece: extruded aluminium, antistatic, powder-coated texture
    - Support arms: sheet steel, antistatic powder-coated texture
    - Worktop: three layer particle board, FP/Y E1 version, fire protection class B2
    - Worktop coating: high pressure plastic laminate
    - Cable duct, horizontal: sheet steel, rolled, antistatic powder-coated texture
  - **Colour combination**
    - **Final digit of order number .1:**
      - Worktop: light-grey
      - Metal parts: RAL 7035 light-grey
    - **Final digit of order number .5:**
      - Worktop: beech finish
      - Metal parts: RAL 7021 dark-grey
  - **Load rating**
    - 1500 N (static surface load)
  - **Standards**
    - ESD version
    - IEC 61340 electrostatics
    - DIN 68761 for worktop
    - EN 438 HGS class for high pressure plastic laminate
  - **Supply schedule**
    - 1 Corner panel
    - 1 Worktop support complete with crosspiece
    - 2 Stabilizers and cable duct
    - 1 Support foot, can be set for desk heights, 680-760
    - Mounting material
  - **How supplied**
    - Pre-assembled modules

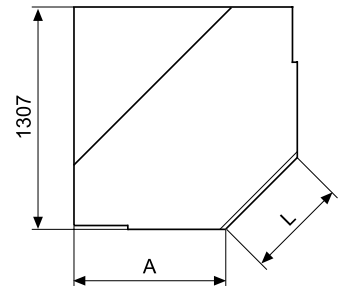

CON00032

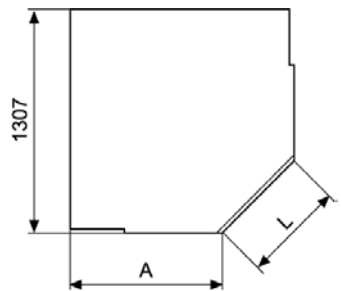

CON00033

A	L	Model	Order-no.	UP
700	880	Trapezoid corner	04.252.558.x	1 unit
800	740	Trapezoid corner	04.252.559.x	1 unit
900	600	Trapezoid corner	04.252.560.x	1 unit
1000	460	Trapezoid corner	04.252.561.x	1 unit
700	880	Trapezoid wall corner	04.252.562.x	1 unit
800	740	Trapezoid wall corner	04.252.563.x	1 unit
900	600	Trapezoid wall corner	04.252.564.x	1 unit
1000	460	Trapezoid wall corner	04.252.565.x	1 unit

## Knürr Elicon® Wall Corner Units

A	Model	Order-no.	UP
700	90°, wall	04.252.554.x	1 unit
800	90°, wall	04.252.555.x	1 unit
900	90°, wall	04.252.556.x	1 unit
1000	90°, wall	04.252.557.x	1 unit

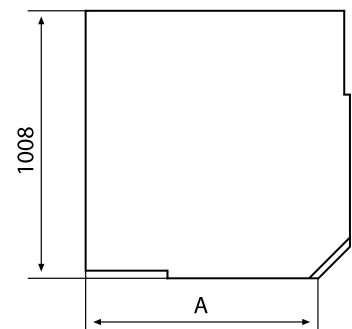

CON00031

## Knürr Elicon® Superstructure Level, Corner

- ESD version for discharging electrostatic charges
  - For utilizing the area above the worktop as storage and functional surface with additional cabling option
  - Worktop height easily adjustable
  - Cable duct integrated in the crosspiece
- **Material / Finish**
    - Superstructure worktop: three layer particle board, FP/Y E1 version, fire protection class B2, melamine coated (directly coated) veneer, ABS 3mm, fine textured, matt
    - Crosspiece: extruded aluminium, antistatic, powder-coated texture
    - Cable duct, horizontal: sheet steel, rolled, antistatic powder-coated texture
  - **Colour combination**
    - **Final digit of order number .1:**
      - Superstructure worktop: light-grey
      - Metal parts: RAL 7035 light-grey
    - **Final digit of order number .5:**
      - Superstructure worktop: beech finish
      - Metal parts: RAL 7021 dark-grey

- **Load rating**
  - 750 N (static surface load)
- **Standards**
  - ESD version
  - IEC 61340 electrostatics
  - DIN 68761 for superstructure worktop
  - DIN 68765 for direct coating
- **Supply schedule**
  - 1 Superstructure worktop
  - 1 Crosspiece
  - Mounting material
- **How supplied**
  - Pre-assembled modules

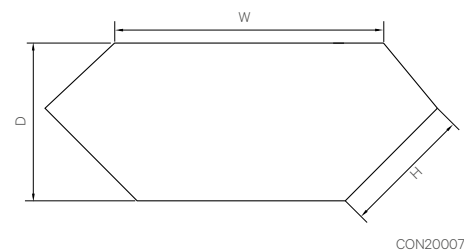

CON20007

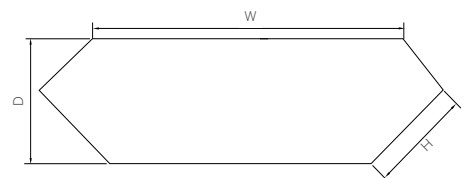

CON20008

W	H	D	Model	Order-no.	UP
824	400	495	90° angled and wall	<b>04.258.032.x</b>	1 unit
1247	400	495	Standard, trapezoid and wall	<b>04.258.033.x</b>	1 unit



Suitable monitor mounting accessories can be found from **page 189**

**Dimensions in mm:** W = Width  
 H = Height  
 D = Depth  
 h = Installation height  
 d = Useful depth  
 L = Length

HU = Standard height unit, 1 HU = 44.45 mm  
 19" = 482.6 mm,  
 (ideal for 19" components in acc. with DIN 41494)

UP = Unit of packaging  
 kg = Weight

**Conversion:** 1 inch = 25.4 mm  
 1 pound = 453.6 g

Replace „x“ with the number of your color choice

## Knürr Elicon® Superstructure Level, Corner

- ESD version for discharging electrostatic charges
  - For utilizing the area above the worktop as storage and functional surface with additional cabling option
  - Stable crosspiece with spacious, folding, and consequently easily accessible cable duct
  - Easy integration of system components for perfect electricity provision with C-rails and mounting slots
  - Worktop height easily adjustable
  - Can be fitted at any time with keyboard shelves
- **Material / Finish**
    - Superstructure worktop: three layer particle board, FP/Y E1 version, fire protection class B2, melamine coated (directly coated) veneer, ABS 3mm thick, fine textured, matt
    - Crosspiece: extruded aluminium, antistatic, powder-coated texture
    - Support arms: sheet steel, antistatic powder-coated texture
    - Cable duct, horizontal: sheet steel, rolled, antistatic powder-coated texture
  - **Colour combination**
    - **Final digit of order number .1:**
      - Superstructure worktop: light-grey
      - Metal parts: RAL 5003 light-grey
    - **Final digit of order number .5:**
      - Superstructure worktop: beech finish
      - Metal parts: RAL 7021 dark-grey
  - **Load rating**
    - 1500 N (static surface load)
  - **Standards**
    - ESD version
    - IEC 61340 electrostatics
    - DIN 68761 for superstructure worktop
    - DIN 68765 for direct coating
  - **Supply schedule**
    - 1 Superstructure worktop
    - 2 Stabilizers
    - 1 Crosspiece
    - 1 Cable duct
    - Mounting material
  - **How supplied**
    - Preassembled modules

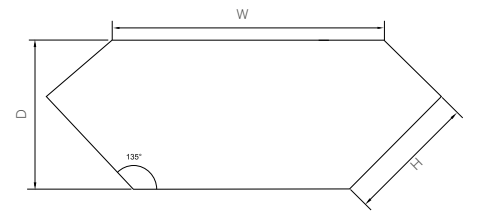

CON20009

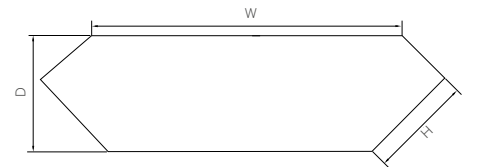

CON00010

W	H	D	Model	Order-no.	UP
907	500	595	90° angled and wall	<b>04.258.036.x</b>	1 unit
1330	500	595	Trapezoid and wall	<b>04.258.037.x</b>	1 unit

## Knürr Elicon® Computer Mounting Side

- Can be mounted on the left, right or both sides on the vertical extrusion (both inside and outside) at any height.
  - Width adjustable: 165-265 mm
- **Material / Finish**
    - Sheet steel, antistatic powder-coated texture
  - **Load rating**
    - 250 N (static surface load)
  - **Note**
    - The lowest mounting position is 80 mm (min. floor clearance)
  - **Supply schedule**
    - 1 Computer shelf
    - Mounting material
  - **How supplied**
    - Flat-packed kit

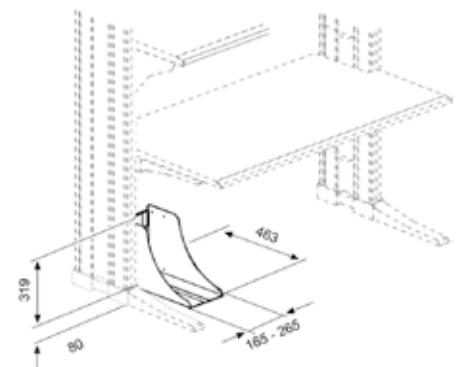

CON00054

W	H	D	Model	Order-no.	UP
				<b>04.208.078.x</b>	1 unit



## ESD workstations

	Knürr ESD workstation	10 <sup>6</sup> - 10 <sup>8</sup> Ohm
	Safety range for personnel 50 kOhm - infinite	
Safety range: MOS components		
Danger area for personnel	Safety area for personnel and MOS components	Danger area for MOS components
10 <sup>3</sup> Ohm	10 <sup>5</sup> Ohm	10 <sup>8</sup> Ohm

- When computers go crazy, alarm systems no longer function or cash registers simply refuse to work, the gremlin at work is quite often easy enough to identify: Static Electricity.

- The constant development of highly integrated circuits results in increasingly more efficient (but also increasingly smaller!) equipment. Therefore it is all the more important to determine the growing sensitivity of **electrostatic sensitive devices (ESD)**. Even voltages of just 100 – 200 volt are enough to damage microprocessors or MOSFETs.

- High voltages are often triggered by modern plastics, artificial fibres in clothing and carpets, and by low humidity in centrally-heated rooms. Depending on the shoe material, speed and humidity, a person walking across a carpet can be loaded with between 2000 and 20,000 volts.

- There is no doubt about it! The safety of electronic components (not to mention the well-being of the operating personnel) can no longer be guaranteed under these conditions.

- In order to safely neutralize static charges at non-hazardous currents, the electric resistance between the respective component and ground must be between 1MΩ and 1GΩ. Worktops made from electrically conductive particle board and special conductive HPL-surfaces offer this defined conductivity. Further we recommend to always connect work-places via a 1MΩ Safety Resistor to building-earth in order to avoid possibly inaccurate earthing resistances on building level.

- With the **ESD workstations from Knürr**, the perfect operational workstation equipment is now available.

- Site insulation in accordance with VDE 0100, § 24 and DIN 57 680 part 2.
- Protection of electronic components against static electricity (EN 61340)



ELI00473

### The Basics

- Generation of electrostatic charges cannot always be prevented. Therefore the discharge must be specifically "influenced". Influenced means: All discharge processes must be run controlled and calculable.

The calculable discharge process is described by the following exponential function:

$$U(t) = U_0 \cdot e^{-t/RC}$$

U<sub>0</sub> = Initial voltage of the capacitor

R = Leakage resistance

C = Capacity

- By activating the equation towards R, an equation is generated with which an ideal leakage resistance can be ascertained.

$$R_0 = \frac{-t_{zul}}{C \cdot \ln(U_0/U_{zul})}$$

- The optimal discharge curve is consequently achieved. Assuming that the voltage (U<sub>0</sub>) must be reduced within 0.1 sec (t<sub>zul</sub>) to 50 V (U<sub>zul</sub>) so that the electrostatic endangered components are not under high voltage for too long, the leakage resistance therefore acts as the regulator for a controlled discharge.

- Of course, for the safety of the endangered components it is also helpful if charges can be prevented before they are generated by equalising the different potentials. Conductive work and unit surfaces, plastic parts made of conductive materials, the connection of all parts with one another and with the ESD body are all required for this purpose.



\*Electrostatic discharge

- Easily accessible connections for ESD potential equalization, e.g. for measuring and soldering equipment must be available at each workstation. A cable is provided for the safe connection between workstation and ESD potential equalization.
- Easy release connection points for wristbands and other potential equalization conductors are also provided.

**Discharge curve of electrostatic charges**

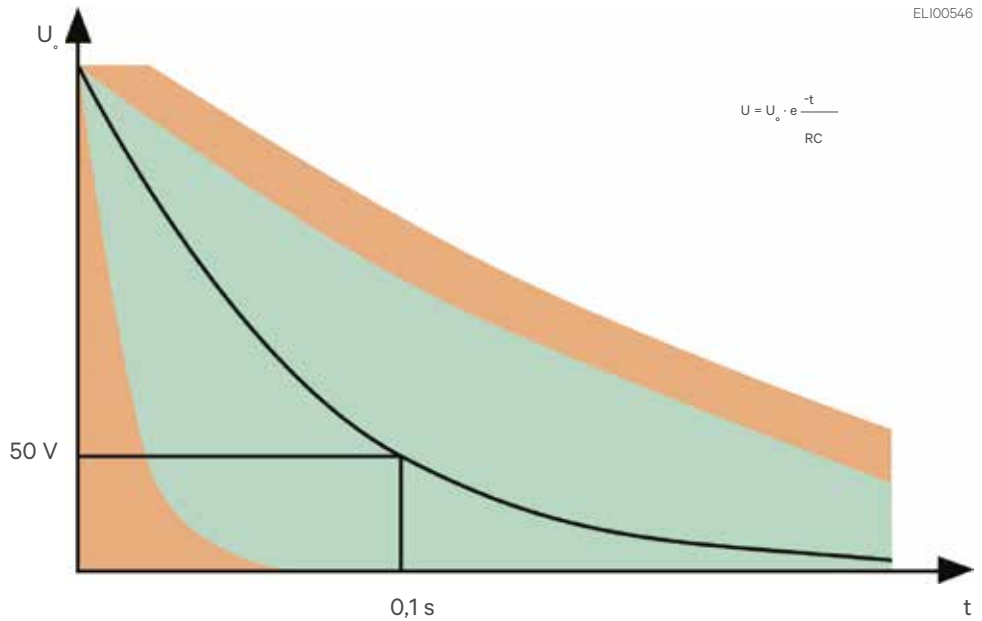

ELI00546

- Also included in safeguarding equipment are drawers and storage spaces inside and outside which are made of conductive material for further preventing charges from building up.
- With Knürr ESD workstations, all the necessary requirements are satisfied. For this very reason, both the complete workstation itself and work pieces, tools and operating personnel are all on an equipotential line. If potential differences occur as a result of rubbing or for whatever other reason, safe charge equalization or charge dissipation via earth is implemented immediately.

**Diverse areas of application**

- Highly sensitive components do not require just direct protection at electronic workstations; the safety equipping of all other work areas is just as important in this respect. They must also be equipped with conductive desks, chairs, racks, transport trolleys and containers.



If you follow the path of electrostatic endangered components via transport – laboratory – test area – production

- goods output control – packaging through to dispatch, it soon becomes evident that ESD room equipment and ESD accessories have become an indispensable necessity.
- Each of these stations is a part of the quality chain, and as with every chain, a single weak link nullifies the capacities of the other segments.

**Knürr ESD workstations provide a comprehensive safety solution to ensure efficiency**

**Conductive materials**

- Last, and certainly by no means least, the safety equipping of Knürr ESD workstations has been made possible with the advances in the development of conductive materials (plastics, laminates, paints). Thanks to these materials we can now successfully unite both **ergonomic requirements** and **modern design** and **safety** in one system.

## Knürr Elicon® Connector Side Panels/Closing Side Panels

- **Connector/closing side panels**
  - Vertical cable routing in the spacious cable duct
  - Sheet steel cable duct covers with hinge function for easy cabling
  - Mounted superstructures (rear), add-on levels, and other components
  - Mounting option for additional foot stabilizer at the rear to increase stability with add-ons
  - Preassembled lock strips for simple and secure worktop mounting (680–760 mm, increment 20 mm). Any work height can be set at any time simply by turning a screw
- **Connector Side Panels**
  - Segmented cable duct cover on the outside and inside
- **Closing Side Panels**
  - Full-length cable duct cover on the outside
  - Segmented cable duct cover on the inside
- **Variants**
  - Type 1**
    - Side panel with short stabilizer for worktops with depth 700 mm
  - Type 2**
    - Side panel with long stabilizer for worktops with depths 800/900/1000 mm
- **Material/finish**
  - Extruded aluminum with die cast aluminum stabilizer and head piece, antistatic powder-coated texture
  - Cable duct cover: sheet steel, rolled, antistatic powder-coated texture
- **Color combination**
  - Final digit of order number .2:**
    - Metal parts: RAL 7035 light grey
    - Design elements: RAL 5003 sapphire blue
  - Final digit of order number .9:**
    - Metal parts and design elements: RAL 7021 dark grey
- **How supplied**
  - Preassembled modules

Knürr Elicon® Connector Side Panels					
W	H	D	Model	Order-no.	UP
760	650		Type 1	04.252.150.x	1 unit
760	800		Type 2	04.252.151.x	1 unit
1250	800		Typ 2	04.252.155.x	1 unit
1656	800		Type 2	04.253.151.x	1 unit
2064	800		Type 2	04.253.152.x	1 unit

Knürr Elicon® Closing Side Panels					
W	H	D	Model	Order-no.	UP
760	650		Type 1	04.252.160.x	1 unit
760	800		Type 2	04.252.161.x	1 unit
1250	800		Typ 2	04.252.165.x	1 unit
1656	800		Type 2	04.253.161.x	1 unit
2064	800		Type 2	04.253.162.x	1 unit

## Knürr Elicon® Side Piece Cover, Full-Length Optional for external side piece

- **Material/Finish**
  - Sheet steel, rolled, antistatic powder-coat textured
- **Colour combination**
  - Final digit of order number .1:**
    - RAL 7035 light-grey
  - Final digit of order number .9:**
    - RAL 7021 dark-grey
- **Supply schedule**
  - 1 Side piece

W	H	D	Order-no.	UP
760			04.250.362.x	1 unit
1250			04.250.367.x	1 unit
1656			04.250.364.x	1 unit
2064			04.250.365.x	1 unit



CON20105

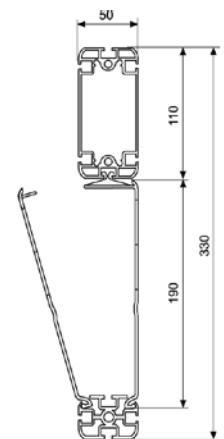

CON00065



CON20107

## Knürr Elicon® Working Level ESD version

- ESD version for discharging electrostatic charges
  - Working level designed as sliding top for convenient access to the horizontal cable duct
  - The working level can be mounted at any height between two side panels and can be varied in the height at any time
  - Worktop (30 mm) with ergonomically shaped front edge
  - Spacious horizontal cable duct, can be accessed via sliding worktop and folding mechanism
  - Cable duct with integrated C-rail for mounting installation components and mounting slot for general accessories
- **Material / Finish**
    - Crosspiece: extruded aluminium, antistatic, powder-coated texture
    - Support arm: sheet steel, antistatic powder-coated texture
    - Worktop: three layer particle board, FP / Y E1 version, fire protectionclass B2, volume conductive
    - Worktop coating: high pressure plastic laminate
    - Cable duct, horizontal: sheet steel, rolled, antistatic powder-coated texture
- **Color**
    - Worktop: light-grey
    - Metal parts: RAL 7035 light-grey
- **Load rating**
    - 1500 N (static surface load)
- **Standards**
    - DIN 68761 for worktops
    - EN 438 HGS class for high pressure plastic laminate
    - EN 61340 for electrostatic
- **Supply schedule**
    - 1 worktop
    - 1 crosspiece
    - 2 desk stabilizers
    - 1 cable duct
    - 1 detailed mounting instructions
    - Mounting material
- **How supplied**
    - Preassembled modules

W	H	D	ESD	Order no.	UP
800		900	•	04.272.110.1	1 unit
1200		900	•	04.272.111.1	1 unit
1600		900	•	04.272.112.1	1 unit
1800		900	•	04.272.113.1	1 unit
2000		900	•	04.272.114.1	1 unit

## Knürr Elicon® Superstructure Level Standard, ESD version

- ESD version for discharging electrostatic charges
  - For utilizing the area above the worktop as storage and functional surface with additional cabling option
  - Worktop height easily adjustable
  - Cable duct integrated in the crosspiece
  - Tilttable 0–10°
  - Worktop thickness: 30 mm
- **Material / Finish**
    - Superstructure worktop: three layer particleboard, FP / Y E1 version, fire-protectionclass B2, melamine coated (directly coated) veneer, ABS 3mm thick fine textured, matt
    - Cable duct, horizontal: sheet steel, rolled, antistatic powder-coated texture
- **Color**
    - Superstructure worktop: light-grey
    - Metal parts: RAL 7035 light-grey
- **Load rating**
    - 750 N (static surface load)
- **Standards**
    - DIN 68761 for superstructure worktop
    - DIN 68765 for direct coating
    - EN 61340 for electrostatic
- **Note**
    - Caution with use in tilted state; use edge strip to prevent sliding
- **Supply schedule**
    - 1 superstructure worktop
    - 1 cable duct
    - Mounting material
- **How supplied**
    - Preassembled modules

W	H	D	ESD	Order no.	UP
800		400	•	04.278.025.1	1 unit
1200		400	•	04.278.016.1	1 unit
1600		400	•	04.278.017.1	1 unit
1800		400	•	04.278.018.1	1 unit
2000		400	•	04.278.019.1	1 unit

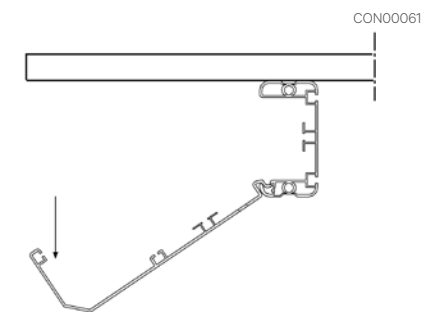
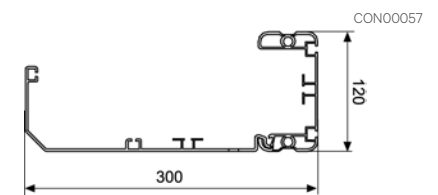
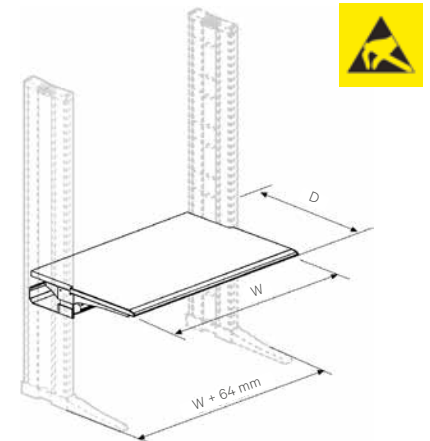

CON00062

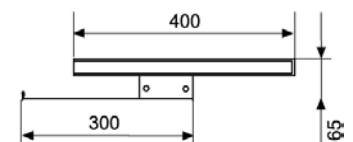
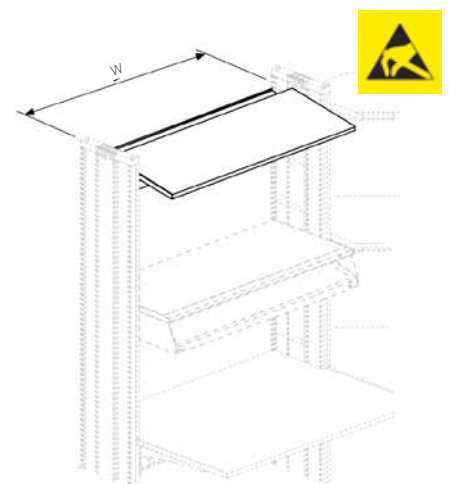

CON00075

## Knürr Elicon® Superstructure Level System, ESD version

- ESD version for discharging electrostatic charges
  - Superstructure level designed as sliding top for convenient access to the horizontal cable duct
  - For utilizing the area above the worktop as storage and functional surface with additional cabling option
  - Stable crosspiece with spacious, folding, and consequently easily accessible cable duct
  - Easy integration of system components for perfect electricity provision with C-rails and mounting slots
  - Worktop height easily adjustable
  - Can be fitted at any time with keyboard shelves
  - Worktop thickness: 30 mm
- **Color**
    - Superstructure worktop: light-grey
    - Metal parts: RAL 7035 light-grey
  - **Load rating**
    - 1500 N (static surface load)
  - **Standards**
    - DIN 68761 for superstructure worktop
    - DIN 68765 for direct coating
    - EN 61340 for electrostatic
  - **Supply schedule**
    - 1 superstructure level
    - 2 stabilizers
    - 1 crosspiece
    - 1 cable duct
    - Mounting material
  - **How supplied**
    - Preassembled modules
- **Material / Finish**
    - Superstructure worktop: three layer particleboard, FP / Y E1 version, fire-protection class B2, melamine coated (directly coated) veneer, ABS 3mm thick fine textured, matt
    - Crosspiece: extruded aluminium, antistatic, powder-coated texture
    - Support arms: sheet steel, antistatic powder-coated texture
    - Cable duct, horizontal: sheet steel, rolled, antistatic powder-coated texture

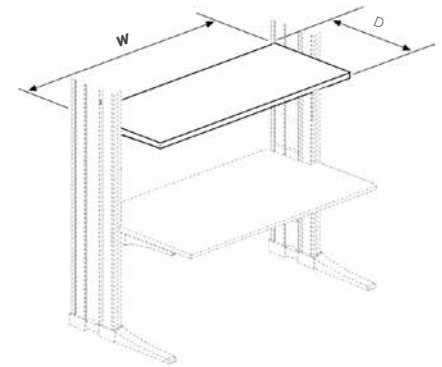

CON00064

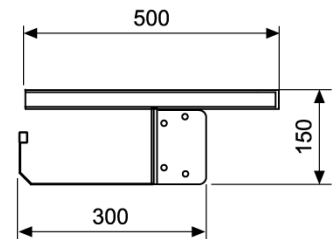

CON00037

W	H	D	ESD	Order no.	UP
800		500	•	<b>04.278.025.1</b>	1 unit
1200		500	•	<b>04.278.026.1</b>	1 unit
1600		500	•	<b>04.278.027.1</b>	1 unit
1800		500	•	<b>04.278.028.1</b>	1 unit
2000		500	•	<b>04.278.029.1</b>	1 unit



Suitable monitor mounting accessories can be found from page **189**

**Dimensions in mm:** W = Width  
 H = Height  
 D = Depth  
 h = Installation height  
 d = Useful depth  
 L = Length

HU = Standard height unit, 1 HU = 44.45 mm  
 HP = Horizontal pitch  
 OU = Office unit  
 19" = 482.6 mm, (ideal for 19" components in acc. with DIN 41494)  
 UP = Unit of packaging

**Conversion:** 1 inch = 25,4 mm  
 Replace „x“ with the number of your color choice

## Knürr Elicon® 90° Wall Corner, ESD



- ESD version for discharging electrostatic charges
  - The ergonomically formed front edge ensures optimal working conditions
  - Height variable for exact adjustment to operator and hardware
  - With support arms for direct connection to the side pieces
  - Spacious horizontal cable duct, can be accessed via removable corner panel and folding mechanism
  - Cable duct with integrated C-rail for mounting installation components and T-slot for mounting general accessories
  - With side panels which can also be used as workstation end points
- **Material / Finish**
    - Crosspiece: extruded aluminium, anti-static, powder-coated texture
    - Support arms: sheet steel, antistatic powder-coated texture
    - Worktop: three layer particle board, FP / Y E1 version, fire protectionclass B2, volume conductive
    - Worktop coating: high pressure plastic laminate
    - Cable duct, horizontal: sheet steel, rolled, antistatic powder-coated texture
  - **Color combination**
    - Worktop: light-grey
    - Metal parts: RAL 7035 light-grey
  - **Load rating**
    - 1500 N (static surface load)
  - **Standards**
    - DIN 68761 for worktops
    - EN 438 HGS class for high pressure plastic laminate
    - EN 61340 for electrostatic
  - **Supply schedule**
    - 1 corner panel
    - 1 worktop support complete with crosspiece
    - 2 stabilizers and cable duct
    - 1 support foot, can be set for desk heights, 680-760 mm
    - Mounting material
  - **How supplied**
    - Preassembled modules

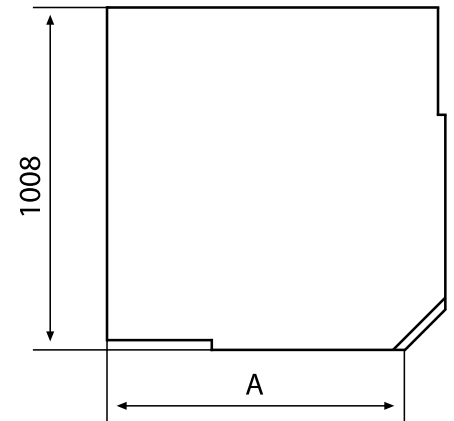

CON00031

W	H	D	A	ESD	Model	Order no.	UP
			900	•	90°, wall	04.272.556.1	1 unit

## Knürr Elicon® Trapezoid Wall Corner, ESD



- ESD version for discharging electrostatic charges
  - The ergonomically formed front edge ensures optimal working conditions
  - Height variable for exact adjustment to operator and hardware
  - With support arms for direct connection to the side pieces
  - Spacious horizontal cable duct, can be accessed via removable corner panel and folding mechanism
  - Cable duct with integrated C-rail for mounting installation components and T-slot for mounting general accessories
  - With side panels which can also be used as workstation end points
- **Material / Finish**
    - Crosspiece: extruded aluminium, antistatic, powder-coated texture
    - Support arms: sheet steel, antistatic powder-coated texture
    - Worktop: three layer particle board, FP / Y E1 version, fire protectionclass B2, volume conductive
    - Worktop coating: high pressure plastic laminate
    - Cable duct, horizontal: sheet steel, rolled, antistatic powder-coated texture
  - **Color combination**
    - Worktop: light-grey
    - Metal parts: RAL 7035 light-grey
  - **Load rating**
    - 1500 N (static surface load)
  - **Standards**
    - ESD version
    - DIN 68761 for worktop
    - EN 438 HGS class for high pressure plastic laminate
    - EN 61340 for electrostatic
  - **Supply schedule**
    - 1 corner worktop
    - 1 worktop support complete with crosspiece
    - 2 stabilizers and cable duct
    - 1 support foot, can be set for desk heights, 680-760 mm
    - Mounting material
  - **How supplied**
    - Preassembled modules

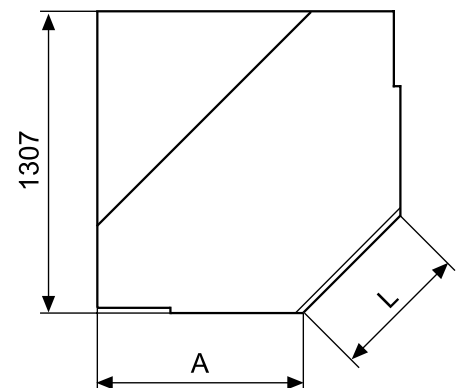

CON00032

W	H	D	A	ESD	L	Model	Order no.	UP
			900	•	600	Trapezoid corner	04.272.560.1	1 unit



## Knürr Elicon® Superstructure Level Corner, ESD Standard depth, 400 mm

- ESD version for discharging electrostatic charges
  - For utilizing the area above the worktop as storage and functional surface with additional cabling option
  - Worktop height easily adjustable
  - Cable duct integrated in the crosspiece
- **Material / Finish**
    - Superstructure worktop: three layer particle board, FP / Y E1 version, fire protection class B2, melamine coated (directly coated) veneer, ABS 3mm thick, fine textured, matt
    - Cable duct, horizontal: sheet steel, antistatic powder-coated texture
  - **Color combination**
    - Superstructure worktop: light-grey
    - Metal parts: RAL 7035 light-grey
  - **Load rating**
    - 750 N (static surface load)
  - **Standards**
    - DIN 68761 for superstructure worktop
    - DIN 68765 for direct coating
    - EN 61340 for electrostatic
  - **Supply schedule**
    - 1 superstructure worktop
    - 1 cable duct
    - Mounting material
  - **How supplied**
    - Preassembled modules

W	H	D	ESD	Model	Order no.	UP
824	400	495	•	90° wall	04.278.032.1	1 unit
1247	400	495	•	Trapez. and trapez. wall	04.278.033.1	1 unit

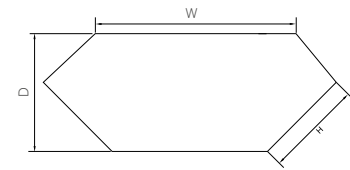

CON20007



CON20008

## Knürr Elicon® Superstructure Level Corner, ESD System depth, 500 mm

- ESD version for discharging electrostatic charges
  - For utilizing the area above the worktop as storage and functional surface with additional cabling option
  - Stable crosspiece with spacious, folding, and consequently easily accessible cable duct
  - Easy integration of system components for perfect electricity provision with C-rails and mounting slots
  - Worktop height easily adjustable
  - Can be fitted at any time with keyboard shelves
- **Material / Finish**
    - Superstructure worktop: three layer particle board, FP / Y E1 version, fire protection class B2, melamine coated (directly coated) veneer, ABS 3mm thick, fine textured, matt
    - Crosspiece: extruded aluminium, antistatic powder-coated texture
    - Support arms: sheet steel, antistatic powder-coated texture
    - Cable duct, horizontal: sheet steel, antistatic powder-coated texture
  - **Color combination**
    - Superstructure worktop: light-grey
    - Metal parts: RAL 5003 light-grey
  - **Load rating**
    - 1500 N (static surface load)
  - **Standards**
    - DIN 68761 for superstructure worktop
    - DIN 68765 for direct coating
    - EN 61340 for electrostatic
  - **Supply schedule**
    - 1 superstructure worktop
    - 2 stabilizers
    - 1 crosspiece
    - 1 cable duct
    - Mounting material
  - **How supplied**
    - Preassembled modules

W	H	D	ESD	Model	Order no.	UP
907	500	595	•	90° wall	04.278.036.1	1 unit
1319	500	595	•	Trapez. and trapez. wall	04.278.037.1	1 unit

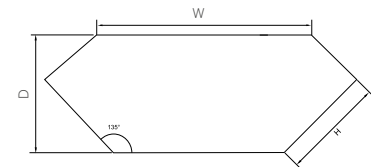

CON20009

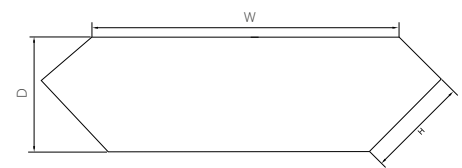

CON20010

**Dimensions in mm:** W = Width  
 H = Height  
 D = Depth  
 h = Installation height  
 d = Useful depth  
 L = Length

HU = Standard height unit, 1 HU = 44.45 mm  
 HP = Horizontal pitch  
 OU = Office unit  
 19" = 482.6 mm, (ideal for 19" components in acc. with DIN 41494)  
 UP = Unit of packaging

**Conversion:** 1 inch = 25.4 mm  
 Replace „x“ with the number of your color choice

## Knürr Elicon® PC Pedestal

- Bonded main unit
  - With passive ventilation from the rear at the top
  - Full glass door and lock at the front
  - Stationary with leveling feet
  - With cable routing set (80 mm diameter) at the rear top for cabling in the vertical cable duct
- Material / Finish**
    - Main unit: Three layer particle board, FP/Y E 1 version, directly coated, fire protection class B2
    - Front door: Full glass door, EMC, 6 mm, clear glass
  - Color combination**

**Final digit of order number .1:**

    - Main unit: Light gray
    - Door: Full glass door, EMC, 6 mm, clear glass

**Final digit of order number .5:**

    - Main unit: Dark gray
    - Door: Full glass door, EMC, 6 mm, clear glass
  - Supply schedule**
    - 1 PC pedestal
    - Mounting material
  - How supplied**
    - Preassembled

W	H	D	w	h	d	Model	Order-no.	UP
363	700	875	312	566	825	Lock (left)	00.320.520.x	1 unit
363	700	875	312	566	835	Lock (right)	00.320.521.x	1 unit



CON20090

## Smaract 19" Pedestal for Knürr Elicon®

- 19" Pedestal, installation height, 12 HU
  - 19" T-slot extrusion for variable mounting of installation components
  - Shortened bottom on the rear metal door
  - Cover panel with cable port on the rear, top
  - For components in accordance with IEC 297-3
- Material**
    - Extruded aluminium
    - Corner connector, die-cast aluminium
    - Covers, powder-coated texture
    - Glass door: sheet steel with single safety glass panel
    - Metal door: sheet steel
  - Model**
    - IP 20
  - Space solution**
    - 82% of the basic surface can be used as space for installation and cable routing
  - Finish**
    - Basic frame: polished
    - Covers, front and rear doors, RAL 7035 light-grey
- Tests**
    - Safety in accordance with EN 50298 and EN 60950
    - Protective conductor/earth in accordance with DIN VDE 0701-1
    - IP test in accordance with DIN EN 60529
  - Supply schedule**
    - 1 Basic frame
    - 2 Closed side panels
    - 1 Shortened rear door
    - 1 Cover panel with cable routing
    - 2 19" Aluminium vertical extrusions, at the front, with T-slot
    - 1 Earthing set
    - 1 Assembly kit
    - 1 Mounting instructions
  - Note**
    - 1 Crosspiece is required for installing the Smaract 19" pedestal for depth 900 mm
  - How supplied**
    - Fully assembled



CON20051



CON20050



CON20051



CON20052

W	H	D	HU	h	Model	Order-no.	UP
600	598	600	12	536	Without door	04.252.600.1	1 unit
600	598	600	12	536	With glass door	04.252.602.1	1 unit
600	598	600	12	536	With metal door	04.252.603.1	1 unit

**Dimensions in mm:** W = Width  
H = Height  
D = Depth  
h = Installation height  
d = Useful depth  
L = Length

HU = Standard height unit, 1 HU = 44.45 mm  
19" = 482.6 mm, (ideal for 19" components in acc. with DIN 41494)

UP = Unit of packaging  
kg = Weight

**Conversion:** 1 inch = 25.4 mm  
1 pound = 453.6 g

Replace 'x' with the number of your color choice

## Crosspiece

- Material / Finish**
  - Sheet steel, powder-coated texture, RAL 7035
- Note**
  - 1 Crosspiece is required for installing the Smaract 19" pedestal in Elicon

W	Order-no.	UP
800	04.250.650.1	1 unit
1200	04.250.651.1	1 unit
1600	04.250.652.1	1 unit
1800	04.250.653.1	1 unit
2000	04.250.654.1	1 unit



CON20053

## Knürr Elicon® 19" Container 19" Accessories for technical workstation

- With side cable entry
  - Fully assembled
  - Adjustable support feet (0-25 mm)
  - Basic frame, polished
- Dimensions**
  - Depth: 900 mm
  - Chassis depth: 640 mm
  - Accessories from Miracel 19" rack, d=640 mm
- Colour combination**

**Final digit of order number .2:**

  - Sheet steel, powder-coated texture, RAL 7035 light-grey
  - Design elements: RAL 5003 sapphire blue
- Supply schedule**
  - 1 19" Container
  - 4 19-inch profile, T-groove
  - 1 decorative profile set, front (without front doors)
  - 1 rear panel
  - 2 side sections
- How supplied**
  - Assembled
- Note**
  - The 19" container cannot be supplied with standard mobile plinth

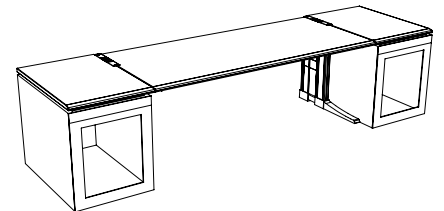
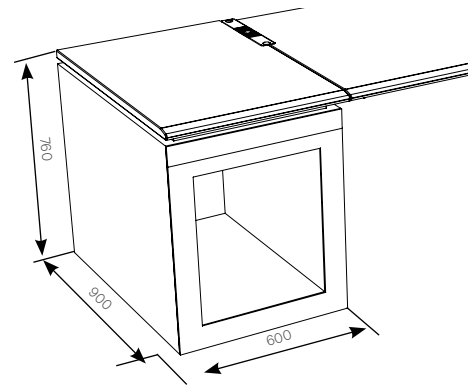

CON20134

W	H	HU	h	Model	Order-no.	UP
600	760-780	12	536	Container, right	01.330.015.x	1 unit
600	760-780	12	536	Container, left	01.330.016.x	1 unit
600	760-780	12	536	Container, centre	01.330.017.x	1 unit

## Front Door, 12 HU For Elicon 19" container

- Glass door**
  - Sheet steel, 1.0 mm
  - Single safety glass panel, 4.0 mm, clear
- Sheet steel door**
  - Sheet steel, 0.75 mm
- Colour combination**

**Final digit of order number .2**

  - Sheet steel, powder-coated texture, RAL 7035 light-grey
  - Design elements, RAL 5003 sapphire blue
- Supply schedule**
  - 1 Glass or sheet steel door
  - 1 Design trim
  - Mounting material

W	H	HU	h	Model	Order-no.	UP
589		12	536	Glass door	01.130.661.x	1 unit
589		12	536	Steel door	01.130.559.x	1 unit



ELI00350



ELI00351



**knürr**  
World of control rooms

[knuerr-panels.com](https://knuerr-panels.com) | Knürr GmbH, Mariakirchener Straße 38, 94424 Arnstorf, Germany ID-Nr. DE 363797731

© 2024 Knürr GmbH. All rights reserved. Knürr® and the Knürr logo are trademarks or registered trademarks of Knürr GmbH. All other names and logos referred to are trade names, trademarks or registered trademarks of their respective owners. While every precaution has been taken to ensure accuracy and completeness herein, Knürr GmbH assumes no responsibility, and disclaims all liability, for damages resulting from use of this information or for any errors or omissions. Specifications are subject to change without notice.